

Serenity-CBRM

Residential remote system

Specification Sheet

R290



Scan for more resources!

Key Features

Chiller

- 10, 8oz drinks per hour at <40°F
- 10.5"W x 14.375"D x 18.125"H
- Weight: 60 lbs
- Refrigerant: R290
- Compressor: 1/9 H.P.
- Operating temperature range: 40°F-100°F
- Electrical: 120v - 2.9 Amps
- Water bath: 1 gallons
- Ice bank: 3 lbs

Tower

- Bottle filling clearance: 7.5"
- 15.5"H
- Weight: 11 lbs

Project:



Low volume sparkling water and chilled still water on tap

Self-contained refrigeration system

CBR-V2C-MINI-SSX tower and CP-JR-UC-BH remote chiller

For residential applications only

Product Overview

- Low profile design for positioning the tower over sinks, low overhead cabinet space, or on tall counters
- Ergonomic handles
- Faucet flow rate: 1.5-2 oz per second
- Adjustable flow rate
- Installation kit included
- Bulkhead fittings for easy hookup to faucet
- Chiller and tower should be positioned within 4' of each other

Line Drawings

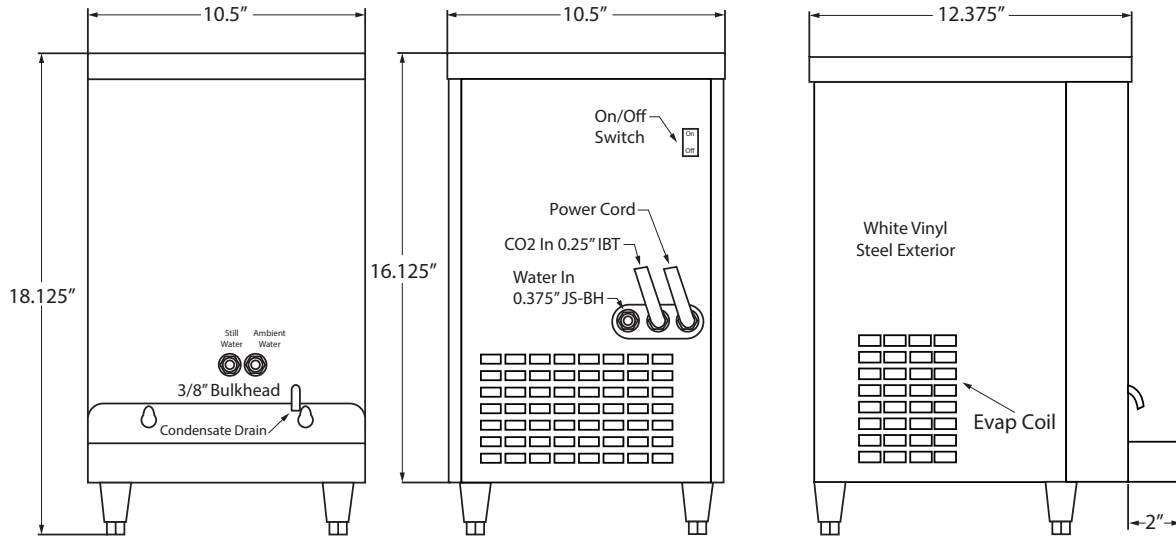

- 3/8" Water inlet connector
- 7' Over flow drain hose
- 7' CO2 hose 1/4" flare fitting
- 8' Electrical cord NEMA 5-15
- 2" legs
- Air intake at rear with air filter
- Allow for 6" rear & side clearance around unit for air flow

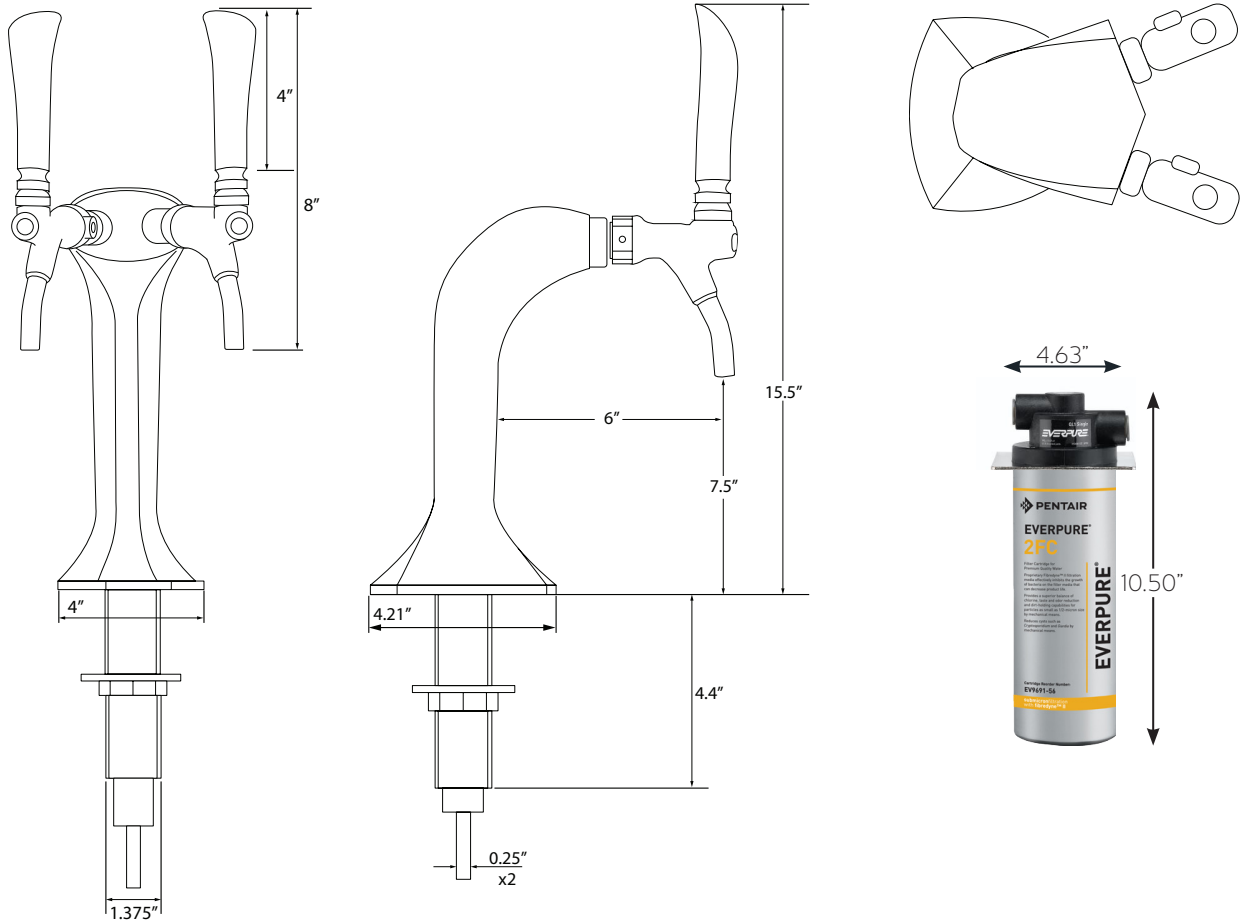

Complete Installation Kit

Included with purchase of unit

Installation kit comes complete with a water filter system, water pressure reducer valve, CO2 regulator, leak block sensor, hose, and angle stop fittings.



Accessories

- 2FC Replacement filter**
Replacement water filter. Compact fibredyne cartridge for CP-JR models



- 2FC-P Replacement Water Filter**
Compact fibredyne cartridge, 1.5 gpm 1,000 gal capacity. Certified PFOA/PFOS and lead-reduction filter, TOC and 0.5 Micron



- CR-SDL-1**
Single sanitary dispense lever that attaches to a self-closing faucet on unit. 1 per faucet. Great for self-service hands-free dispensing applications

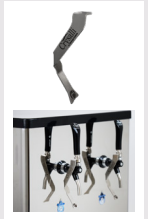

- DP-CT**
Stainless countertop mount drain pan configured with a 1/2" drain tube for direct plumbing



- DP-CT-LD**
Drip pan, less drain, with rubber feet



- RDP-1SSQ-2CL**
12"W x 15.125"D flush mount on counter with splash zone. Cup rest locators in drain grate. Requires square cut for drain pan and hole cut for tower

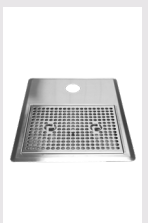

- CR-CWB1**
Cylinder safety restraint wall bracket
- Customer supplied CO2 tank required



Looking for a different style faucet tower? Contact us about configuring this system with the CR-X3PB-COMP tower.

