

Project:



Scan for more info!

Owners Manual
Quick Install
Quick Sizing
Install Layout
Parts List

CR-804-023
Water Boost System

Features

- Increases flow and pressure to sparkling and still water systems
- Ideal for applications where dynamic water pressure to filter systems is lower than 45 PSI
- Maximizes filter life on filtration systems
- Replaceable bladder for maximum system life and simple maintenance
- Self priming pump can run without damage
- Eliminates water pressure fluctuation at point of dispense
- Low profile allows for undercounter installation
- Rigid stainless steel tanks
- Complete turn-key package
- NSF Certified components

Specifications

- Accumulator: 2 gallon stainless steel accumulator
- Pre-charge with 50 PSI air at time of installation
- 90 PSI boost
- Max Draw Down: 0.75 gallons
- Water inlet/outlet connections: 3/8" JG push-fit connections
- Operating temperature range: 34°-120°F
- Electrical: 115 VAC/1 Amp
- Weight: 13 lbs
- 13"W x 13.5"D x 9.5"H
- Install water boost prior to filtration system

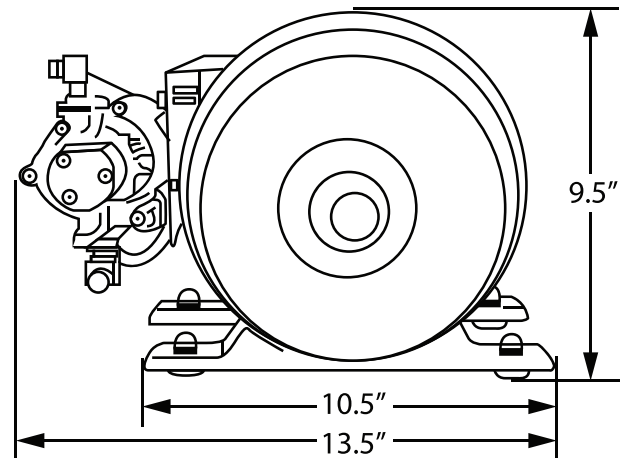
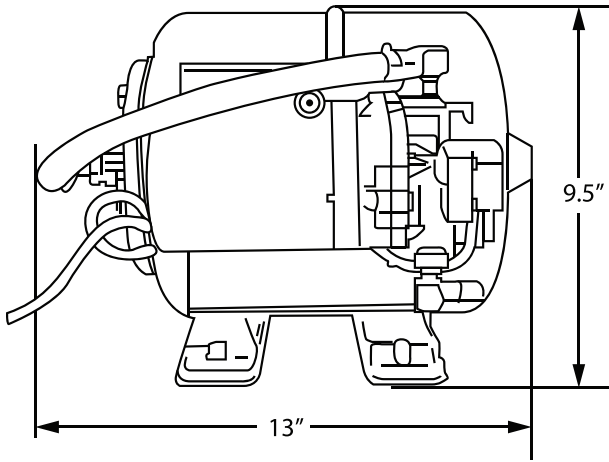

Plumbing Sequence for water boost system

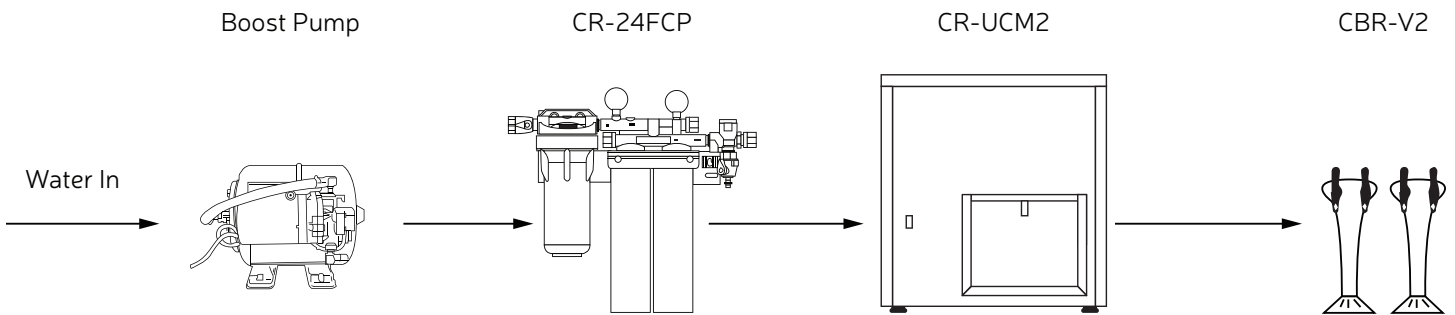

Optional Accessories:

- **KSM24M**
 Wall Mount Shelf
 28" W x 18"D x 12"H

