

CR-CPSW-DI

Drop-In Chilled Still Water
Glass Filling Station



Drop-in, non-mechanical ice-cooled chilling chilled still glass filling station. Pre-assembled with single-faucet draft tower. Suitable for medium volume service stations and hospitality applications.

Features

- Signature Crysalli styling CBR-V1C chrome draft tower with stainless steel tubing and faucet
- Glass fill station with 12.375" clearance
- Self-closing, push lever or pull handle dispense action faucet. Faucet can be used without lever and configured to stay open
- Manual fill: 40 lbs insulated ice storage with multi-loop cold plate and sliding lid
- Reinforced stainless steel recessed drain pan with creased edges for positive seal to counter and 4-point mounting studs
- Removable drain grate with bottle marker
- Requires a counter cutout of 15.375"W x 23.375"D



Accessories

- Water filter system (required):
 - CR-24FC: Twin filter system, compact fibredyne filters, reduce chlorine, taste, odor, color while retaining the good minerals that are essential for bottle quality tasting water, 19"H x 17"W, 5 gpm, 30,000 gal, TOC & ½ micron filtration
 - CR-24FCP: Twin filter system with prefilter, compact fibredyne filters, reduce chlorine, taste, odor, color and organic chemicals while providing exceptional sediment reduction with resistance to premature plugging, 19.25"H x 21.75"W, 5 gpm, 30,000 gal, TOC & ½ micron filtration
- Install kit (required):
 - CR-KIT-CPS: Installation kit for CR-CPS model series, includes water filter fittings, 50 psi water pressure reducer valve, angle stop adaptor, and 8' 3/8 hose
- Dispense levers:
 - CR-SDL-1: Single sanitary dispense lever that attaches to a self-closing faucet on unit. 1 per faucet. Great for self-service hands-free dispensing applications



CR-CPSW-DI

Drop-In Chilled Still Water
Glass Filling Station



Scan for more resources!

Line Drawings

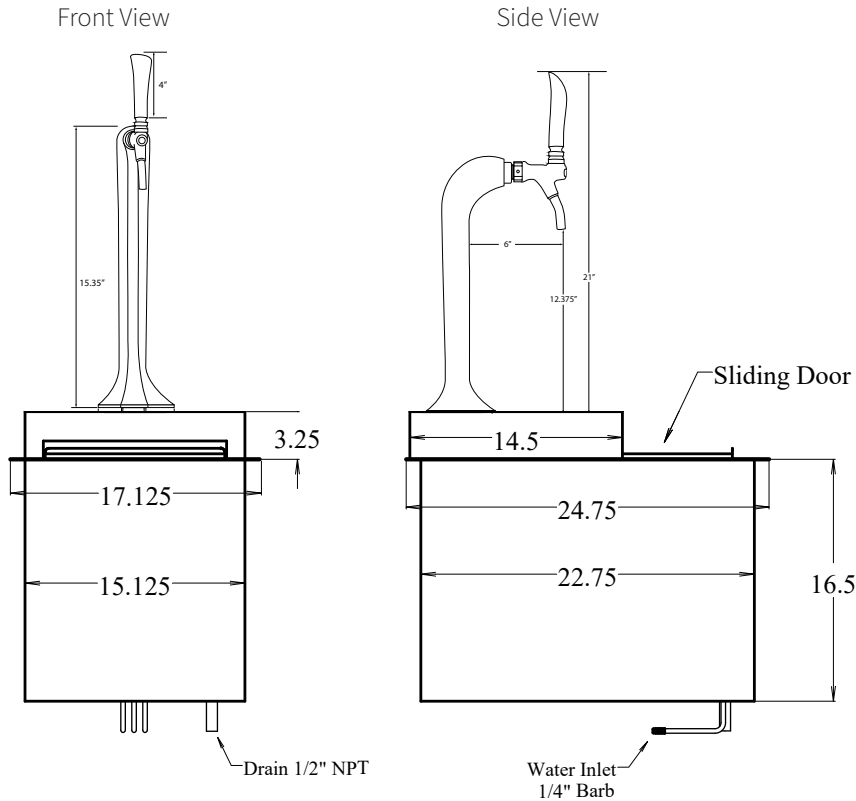

- 3/8" Water inlet connector
- 3/8" Drain pan hose 6'

- 1/2" ice bin drain fitting
- Slide open bin door

Width	17.125"
Depth	24.75"
Height	40.75"
Cup fill clearance	12.375"
Ice storage	40 lbs
Weight	90 lbs