

CR-GFS-V1L

Filtered Water Glass Filling Station



Drop-in, flush mount filtered ambient water glass filling station. Pre-assembled and pre-plumbed with draft tower and water filter manifold mounted to the drain pan. Suitable for medium volume service stations and hospitality applications.

Features

- Signature Crysalli styling CBR-V1C chrome draft tower with stainless steel tubing and faucet
- Glass fill station with 12.375" clearance
- High flow rate up to 2oz per second
- Self-closing, push lever or pull handle dispense action faucet. Faucet can be used without lever and configured to stay open
- Reinforced stainless steel recessed drain pan with creased edges for positive seal to counter and 4-point mounting studs
- Removable drain grate with bottle marker
- Requires a counter cutout of 8.375"W x 13.75"L and water/drain drain within 6'



Accessories

- Water filter replacement:
 - 2FC: Compact fibredyne cartridge, 1.5 gpm 6,000 gal capacity
 - 2FC-P: Compact fibredyne cartridge, 1.5 gpm 1,000 gal capacity. Certified PFOA/PFOs and lead-reduction filter, TOC and 0.5 micron



Complete installation kit (included with purchase of unit):

The unit comes standard with a filter system built on. Installation kit comes complete with anglestop 2 way split adaptor, direct quick connect adaptor, locking clips, 12' of 3/8" OD water inlet tubing, 6' of 1/2" drain hose with drain fitting and faucet spanner wrench.

CR-GFS-V1L

Filtered Water Glass Filling Station



Scan for more resources!

Line Drawings

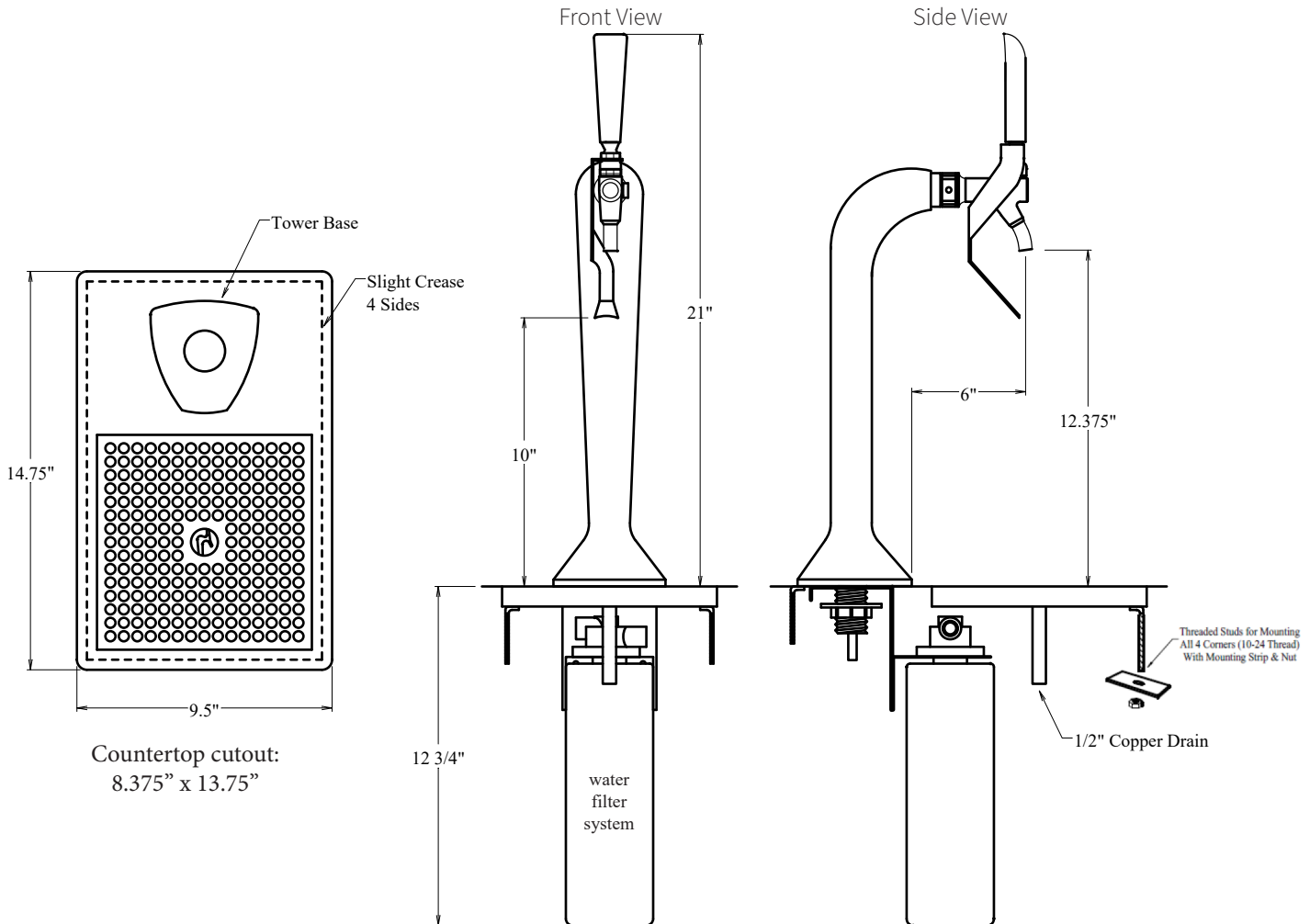

- 3/8" Inlet & outlet filter manifold
- 1/2" Copper drain stub
- 1" Deep drain pan
- Four, 10-24 threaded mounting studs with brackets and locking nuts
- Allow 2.5" clearance below water filter cartridge for easy replacement

Width	9.5"
Depth	14.75"
Height (with filter)	33.75"
Bottle fill clearance	12.375"
Weight	19 lbs

Issued 2/25/2026