

Project:



**Scan for more info!**

Owners manual  
Quick install  
Quick sizing  
Install layout  
Parts list

## **CBDS-P2000-SW** **Undercounter Beverage Chiller**



### **Fountain Dispense Non-carb Chiller**

- Undercounter recirculation system keeps water and syrup chilled from the chiller to the beverage dispenser
- Reduced ice consumption compared to cold plate systems
- Durable, easy to clean, stainless steel cabinet
- Reduced counter space need compared to cold plate systems

### **Specifications**

- Dispense capacity: 1, 12 oz drink per minute (Max capacity: 50, 12 oz drinks at this duty cycle)
- Flow rate: 3 oz per second
- Dispense temperature: <45°F
- Self-contained refrigeration system
- Compressor: 1/9 H.P.
- Refrigerant: R134a CFC-free
- Electrical: 120 VAC
- Minimum amps: 3.3
- Water Bath: 2.5 Gallons
- Ice Bank: 6 lbs
- Dry Weight: 80 lbs
- 11.75"W x 17.5"D x 16.5"H

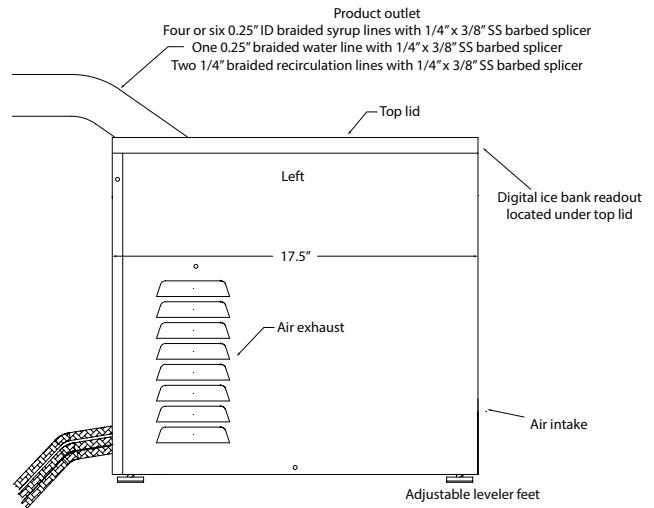
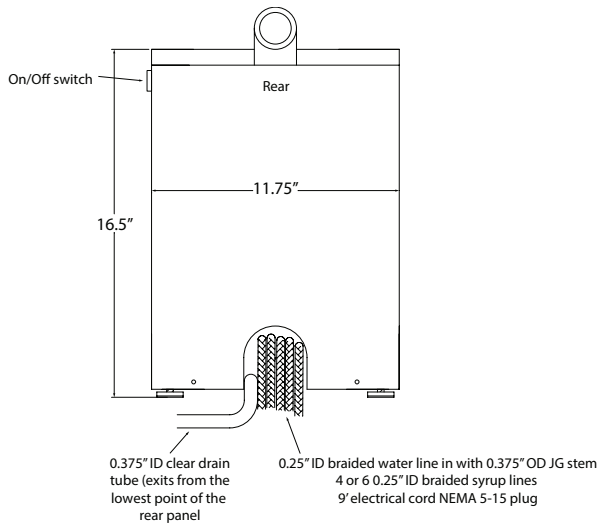

|                  | CBDS-P2000-SW-R4                                       | CBDS-P2000-SW-R6 |
|------------------|--|------------------|
| Coil quantity    | 4 syrup coils  | 6 syrup coils    |
| Coil description | 6 foot stainless steel tubing 0.25" OD with 0.02" wall |                  |

## Accessories:

- **CR-14FCP with Prefilter**
  - **CR-14FC without Prefilter**
- Filtration systems feature one 4FC Fibredyne technology, quick change, sanitary cartridge. T.O.C. capacity 15,000 gal at 2.5 GPM.



- **CBDS-KIT-SW-R4/6**
- Kit includes: Beverage hose, stainless steel fittings, barbed splicers, U-bend, oetiker clamps, John Guest fittings, leak block detector, insulation tape, etc.



- **CR-TFB1**
- Thermostatic fan box recommended anytime a remote chiller is installed in a cabinet



- **CR-4V-BIB-KIT**
  - **CR-6V-BIB-KIT**
- Backroom kit, 4 or 6 BIB pumps, two wide by two high flat shelves



- **CBDS-06002**
  - **CBDS-08002**
- Insulated bundle with barrier tubing (six or eight 3/8" OD product and two 3/8" recirc)



- **CM-T-4V-PBV**
  - **CM-T-6V-PBV**
- Four or six valve, postmix soda, "T" tower with LED dispense buttons and an integrated base and drip pan



- **CR-6-JD**
- 6 product, non-carb, bar gun

